

## AIDS TO PROFESSIONAL FORESTRY PRACTICE

# P.O.I.N.T SAMPLING

ROBERT MARTY  
DEPARTMENT OF FORESTRY  
MICHIGAN STATE UNIVERSITY



MICHIGAN STATE  
UNIVERSITY  
EXTENSION

MSUE Bulletin E-1757.  
Revised August, 1999.

MSU is an Affirmative Action/Equal Opportunity Institution. Program and materials are open to all without regard to race, color, national origin, gender, religion, age, disability, political beliefs, sexual orientation, marital status, or family status.

## INTRODUCTION

Point sampling is an efficient way of estimating the basal area and volume of forest stands. It is widely used because it is simple and economizes on field time. Point sampling can be done in different ways depending on the kind and accuracy of information wanted. It is often used in three different situations in forest management: in stand reconnaissance to provide rough (precision = 30%) but unbiased estimates of species composition, basal area and volume; in compartment examination to provide more accurate estimates (precision = 10%) of site and stand characteristics needed for management planning; and in timber appraisal where still more accurate estimates (precision = 5%) of merchantable timber volumes are wanted.

**HOW POINT SAMPLING WORKS.** In point sampling, the area sampled is different for trees of different sizes. This is done by viewing trees around a sample point through an angle gauge or prism. Figure 1 shows the basic idea. When the angle used is 1.736 degrees, any 10-inch tree within 27.5 feet of the sampling point will appear larger than the projected angle, and so will be selected for sampling. Thus, 10-inch trees are sampled over a circular plot of 0.05454 acres.

Larger trees are sampled over a larger area. A 20-inch tree will appear larger than an angle of 1.736 degrees out to 55 feet from plot center, indicating a sampling area of 0.21816 acres, twice the radius and four times the area sampled for 10-inch trees. The unique feature of point sampling, then, is that trees are sampled with a probability proportional to their basal area. So the area sampled for large trees is much greater than the area sampled for small trees. Point sampling concentrates on the larger trees which contribute most to basal area and volume.

Figure 1 also demonstrates another interesting and useful characteristic of point sampling. Each sample tree--each tree larger than the projected angle--represents a fixed basal area per acre regardless of its size. Each sample tree represents a basal area of 10 square feet per acre for an angle of 1.736 degrees. Ten square feet is that angle's "basal area factor" or BAF. So the average number of sample trees per point, multiplied by the basal area factor, gives an estimate of basal area per acre.

Figure 1

### How Point Sampling Works

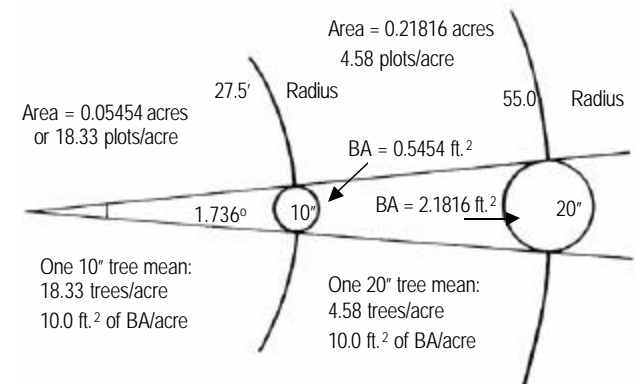

## PRISMS

The prism is the most widely used instrument in point sampling, although various kinds of angle gauges also are used. Prisms with a basal area factor of 10.0 are commonly used in Michigan. However, prisms can be purchased with different basal area factors, and it is sometimes useful to have a 20-factor prism as well as a 10-factor one. Then you can use the prism which will produce a count of 5 to 10 trees per point. Use the 10-factor prism for stands with basal areas up to 100 square feet per acre, and the 20-factor prism for stands with more than 100

square feet of basal area per acre. Do not change prism BAF from plot to plot within a stand. This just makes calculations more complicated.

When you first receive your prism, measure its basal area factor accurately. There's a procedure for doing this in the appendix. If your prism is more than 1 percent away from its intended basal area factor, return it for another until you get one that's right. Don't use an uncalibrated prism. It will cause an unknown amount of systematic bias. And, don't use a calibrated prism which is more than 1 percent off, or you will have more work to do in calculating basal areas and volumes.

**Figure 2**

**A Prism Holder**

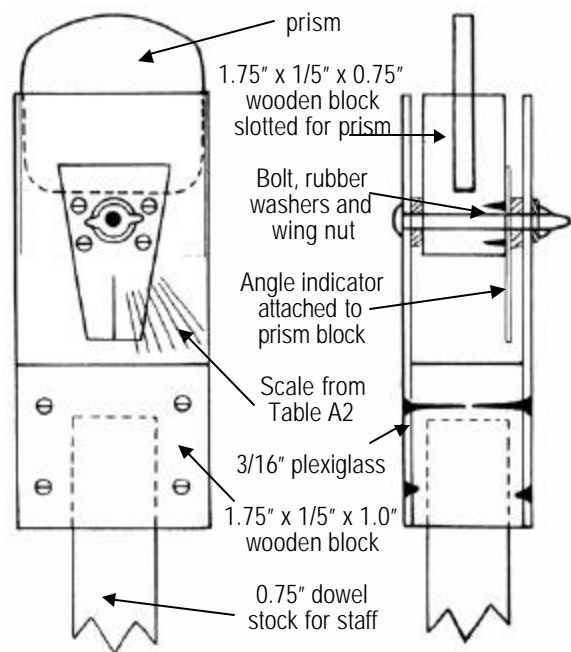

Currently, prisms are sold without a mounting. They are simply wedge-shaped pieces of glass of various shapes. Prisms need mounting so that they can be accurately pivoted from the horizontal for sampling on sloping ground. Figure 2 shows drawings for a mounting you can make yourself. The mounting should be attached to a staff which positions the top of the prism at 4.5 feet above the ground. This will help you use the prism correctly.

**SAMPLE SIZE.** In stand reconnaissance, take 3 to 7 well-spaced point samples, depending on stand size. For compartment examination, take 10 to 100 point samples according to the following schedule.

SIZE OF STAND Acres	NUMBER OF SAMPLING POINTS
0-10	10
11-40	1 point per acre
41-80	$40 + (\text{acres} - 40)/2$
81-240	$60 + (\text{acres} - 80)/4$
240 +	100

This schedule usually will provide a 10 percent precision of estimate, at the 90 percent confidence interval, for stands of 40 acres or more. You must take approximately four times this number of samples if you wish to achieve a 95 percent confidence interval. See the appendix for more on sample size.

**LOCATING SAMPLE POINTS.** Sample points can be located randomly or systematically within the stand. However, systematic sampling usually is used because it is easier and less time consuming. Sample points are evenly spaced along parallel cruise lines oriented to cross contour lines approximately at right angles. This provides a distribution of sample points which have a good chance of encountering varying stand conditions in proportion to their occurrence.

Sampling studies indicate that systematically located points usually provide estimates with equal or even greater precision than an equal number of random sample points. So, random sampling formulas for calculating sampling means and variances are commonly applied to systematic samples, even though the statistical assumptions or random sampling are not met.

All plots should be located at least one chain from stand boundaries to avoid edge bias. Edge bias occurs when a point is located close enough to a stand boundary so that part of the area sampled falls outside the stand.

**SELECTING AND MEASURING SAMPLE TREES**

**SELECTING SAMPLE TREES.** Figure 3 shows how a prism displaces the image of a tree. Sample trees are those which the prism displaces less than their full width at dbh. Use your prism carefully and correctly to avoid significant systematic measurement error:

- Locate and sight your prism correctly. The prism is held 4.5 feet above the sampling point, and rotated in that position. If you use a staff with your prism holder it will help you rotate the prism correctly. If you stand upright to sight through your prism, you will tend to site trees at your eye level rather than at 4.5 feet above the ground. This means that you will systematically undercount.
- If a point falls on sloping ground, determine the maximum slope percent perpendicular to the contour through the sampling point. Then pivot your prism from the horizontal by



tion (such as yield tables and functions that do not require individual tree data), usually are available and will provide a reasonably accurate estimate of stand growth rate. Also, if the stand has been measured before, a comparison of stand volume "then" with stand volume "now" provides the best estimate of periodic stand growth.

## CALCULATIONS

One of the advantages of point sampling is that most calculations are easy to make.

### 1. BASAL AREA PER ACRE:

**BA/acre** = BAF (Total Tree Tally/Number of Sample Points)

Example:  $10(359/48) = 74.8$  square feet per acre

### 2. TOTAL CUBIC FOOT VOLUME OF STEMWOOD PER ACRE:

Cuft./acre = 0.42 (BA/acre) (Ave. Tot. Hgt.)  
Example:  $0.42(74.8) (62) = 1,948$  cuft./acre

### 3. CORDWOOD VOLUME PER ACRE – PRELIMINARY ESTIMATE

Rough cords/acre = (Ave. Tree Tally/Point + Avg. Bolt Tally/oint) / 2  
Example:  $(7.5 + 26) / 2 = 16.75$  cords/acre

### 4. SAWTIMBER VOLUME PER ACRE – PRELIMINARY ESTIMATE

Scrib. MBF/acre = 0.6 (Avg. No.r of Sawlogs per Point)  
Example:  $0.6 (12.4) = 7.4$  MBF per acre.

The merchantable volume calculations above (calculations 3 and 4) provide preliminary estimates only. More accurate estimates of volume are needed for compartment examination and timber appraisal. They can be made by classifying sample trees by merchantable height class,

and using a separate volume factor for each class from appendix Table A4. Table 1 illustrates this calculation procedure, as well as the procedure for estimating the number of trees per acre by diameter class. The data in Table 1 represent a sample of 48 points.

**Table 1**

### Calculation Procedures for Point Sampling

Merchant. Hgt. Class (16' logs)	No. of Trees (48 pts)	Average /Point	Volume Factor (Table A4)	Volume /Acre (Mbf)
1.0	43	0.896	750	672
1.5	184	3.833	1050	4024
2.0	110	2.292	1350	3094
2.5	15	0.312	1600	502
3.0	7	0.146	1870	273
Total				8,565
DBH Class (inches)	No. of Trees (48 pts)	Average /Point	Expansion Factor (Table A5)	Trees /Acre
10	40	0.833	18.3	15.2
12	111	2.312	12.7	29.4
14	123	2.562	9.4	24.1
16	63	1.312	7.2	9.4
18	15	0.312	5.7	1.8
20	7	0.146	4.6	0.7
Total				80.6

## SOME REFERENCES

BEERS, T.W. AND C. I. MILLER  
1964. Point Sampling: Research Results, Theory and Application. Purdue Agric. Expt. Sta. Research Bul. 786. 46 p. (Standard reference)

BEERS, T.W.  
1969. "Slope Correction in Horizontal Point Sampling" Journal of Forestry 67:188-192. (Compares three ways of making slope corrections)

BRUCE, DAVID  
1955. "A New Way to Look at Trees" Journal of Forestry 53:163-167. (The first discussion of prisms in point sampling)

DILWORTH, J. R. AND J. F. BELL  
1977. Variable Plot Cruising. Oregon State Univ. Book Stores Inc. Corvallis. 130 p. (Standard reference and field manual for western conditions)

GROSENBAUGH, L.R.  
1952. "Plotless Timber Estimates—New, Fast, Easy." Journal of Forestry 50:32-37. (First discussion of point sampling in the U.S.)

EVERY, T.E. AND H.E. BURKHART.  
1983. "Forest Measurements". McGraw-Hill, Inc. 331 p. (Includes a good discussion on point sampling.)

# APPENDIX

## PRISM CALIBRATION PROCEDURE

The following procedure, adapted from Dilworth and Bell (1977) will allow you to determine accurately the actual basal area factor of a prism.

1. Set up a target exactly one foot in width on a true vertical backing of contrasting color, at table height.
2. Place a table on a line extending from the target at 90 degrees, so that its center is 33.0 feet from the target for a 10-factor prism, and 23.4 feet from the target for a 20-factor prism.
3. Tape a large sheet of blank paper to the table top, and on the paper draw the line of sight exactly perpendicular to the target.
4. Move the prism along the line, and at right angles to it, until the target width is exactly displaced. Mark this position on the paper. Repeat the alignment at least five times, marking the point of alignment each time.
5. Measure the distance from the target to each alignment mark on the paper, and average these distances to the nearest 1/1000 foot.
6. Calculate the prism's actual basal area factor using the following formula:

$$\text{BAF} = 43,560/d + 4(d^2)$$

when d is the average distance in feet

For example, if the average of distances were 32.897 feet, then

$$\text{BAF} = 43,560/32.897 + 4(32.897^2) = 10.06$$

For example, if the per acre volume estimates for the first five sampling points were: 12.1, 16.4, 9.2, 11.7 and 20.3 cords per acre, then average volume is 13.9 cords, the standard deviation is 4.4 cords and the coefficient of variation is  $100(4.4/13.9) = 32\%$ . Sample size can be adjusted after some samples have been taken by estimating the coefficient of variation in this way, and referring to the table above.

**Table A1**

### Sample Sizes for Point Sampling

Coeff. of Variation (percent)	Desired Precision of Estimate		
	30%	10%	5%
Sample Needed When Probability = 90%			
30	1	9	36
40	2	16	64
50	3	25	100
60	4	36	144
70	5	49	196
80	7	64	256
90	9	81	324
100	11	100	400

**DESIRED PRECISION:** Usually taken as 30% for stand reconnaissance, 10% for compartment examination, and 5% for stumpage appraisal.

**COEFFICIENT OF VARIATION:** The variability of the stand being sampled is defined as the standard deviation of samples expressed as a percent of the mean. Standard deviation is given by:

$$SD = \sqrt{\frac{\sum (x-x)^2}{n-1}}$$

**NUMBER OF SAMPLES NEEDED:** The table shows the number of sampling points needed when the confidence interval is 90 percent. A 95 percent confidence interval requires four times as many samples as is indicated in the table.

**Table A2**

### Prism Rotation on Slopes

Slope %	Rotation %	Slope %	Rotation %
15	11	60	41
20	14	65	44
25	18	70	47
30	21	75	50
35	24	80	53
40	28	85	56
45	31	90	59
50	34	95	62
55	38	100	65

**Table A3**

### Volume Factors

Merchant Length	4-inch top Cordwood Volume	Gross Sawtimber Volume		
		Int. 1/4"	Scrib.	Doyle
0.5	0.9	390	280	150
1.0	1.5	750	530	280
1.5	2.1	1050	790	480
2.0	2.6	1350	1110	740
2.5	3.0	1600	1330	940
3.0	3.4	1870	1580	1220
3.5	3.7	2100	1830	1480
4.0	4.1	2400	2080	1750
4.5		2650	2290	1990
5.0		2800	2560	2300

These volume estimates apply when a 10-factor prism is used. Double these estimates when using a 20-factor prism. The sawtimber volume estimates assume a Girard form class of 78. Adjust the estimates by three percent for every point of departure from 78. These estimates also assume a one-foot stump height and a variable top diameter not less than 6 inches for conifers and aspen, and not less than 8 inches for other species.

**Table A4**

**Qualifying Distances  
for BAF=10**

Distance on the Slope When the Slope Percent is:										
DBH	0	10	20	30	40	50	60	70	80	90
Inches	Distance in Feet									
1	2.7	2.8	2.8	2.8	2.9	2.9	3.0	3.0	3.1	3.2
2	5.5	5.5	5.6	5.6	5.7	5.8	5.9	6.1	6.2	6.4
3	8.2	8.3	8.3	8.4	8.6	8.7	8.9	9.1	9.3	9.6
4	11.0	11.0	11.1	11.2	11.4	11.6	11.9	12.2	12.4	12.8
5	13.7	13.8	13.9	14.0	14.3	14.5	14.8	15.2	15.6	15.9
6	16.5	16.5	16.7	16.9	17.1	17.4	17.8	18.2	18.7	19.1
7	19.2	19.3	19.4	19.7	20.0	20.4	20.8	21.3	21.8	22.3
8	22.0	22.1	22.2	22.5	22.8	23.3	23.8	24.3	24.9	25.5
9	24.7	24.8	25.0	25.3	25.7	26.2	26.7	27.3	28.0	28.7
10	27.5	27.6	27.8	28.1	28.5	29.1	29.7	30.4	31.1	31.9
11	30.2	30.3	30.5	30.9	31.4	32.0	32.7	33.4	34.2	35.1
12	33.0	33.1	33.3	33.7	34.2	34.9	35.6	36.5	37.3	38.3
13	35.7	35.8	36.1	36.5	37.1	37.8	38.6	39.5	40.5	41.5
14	38.5	38.6	38.9	39.3	40.0	40.7	41.6	42.5	43.6	44.7
15	41.2	41.4	41.7	42.1	42.8	43.6	44.5	45.6	46.7	47.8
16	44.0	44.1	44.4	45.0	45.7	46.5	47.5	48.6	49.8	51.0
17	46.7	46.9	47.2	47.8	48.5	49.4	50.5	51.7	52.9	54.2
18	49.5	49.6	50.0	50.6	51.4	52.3	53.5	54.7	56.0	57.4
19	52.2	52.4	52.8	53.4	54.2	55.2	56.4	57.7	59.1	60.6
20	55.0	55.1	55.5	56.2	57.1	58.2	59.4	60.8	62.2	63.8
21	57.7	57.9	58.3	59.0	59.9	61.1	62.4	63.8	65.4	67.0
22	60.5	60.7	61.1	61.8	62.8	64.0	65.3	66.8	68.5	70.2
23	63.2	63.4	63.9	64.6	65.6	66.9	68.3	69.9	71.6	73.4
24	66.0	66.2	66.7	67.4	68.5	69.8	71.3	72.9	74.7	76.6
25	68.7	68.9	69.4	70.2	71.3	72.7	74.2	76.0	77.8	79.7
26	71.5	71.7	72.2	73.1	74.2	75.6	77.2	79.0	80.9	82.9
27	74.2	74.4	75.0	75.9	77.1	78.5	80.2	82.0	84.0	86.1
28	77.0	77.2	77.8	78.7	79.9	81.4	83.2	85.1	87.1	89.3
29	79.7	79.9	80.5	81.5	82.8	84.3	86.1	88.1	90.2	92.5
30	82.5	82.7	83.3	84.3	85.6	87.2	89.1	91.1	93.4	95.7
31	85.2	85.5	86.1	87.1	88.5	90.1	92.1	94.2	96.5	98.9
32	88.0	88.2	88.9	89.9	91.3	93.0	95.0	97.2	99.6	102.1
33	90.7	91.9	91.6	92.7	94.2	96.0	98.0	100.3	102.7	105.3
34	93.5	93.7	94.4	95.5	97.0	98.9	101.0	103.3	105.8	108.5
35	96.2	96.5	97.2	98.3	99.9	101.8	103.9	106.3	108.9	111.6
36	99.0	99.2	100.0	101.2	102.7	104.7	106.9	109.4	112.0	114.8

**Table A5**

**Tree Expansion Factors**

DBH	Expansion Factor	DBH	Expansion Factor
Inches	No. of trees	Inches	No. of trees
1.0	1902.2	19.0	5.1
2.0	458.4	20.0	4.6
3.0	206.2	21.0	4.2
4.0	114.6	22.0	3.8
5.0	73.3	23.0	3.5
6.0	50.9	24.0	3.2
7.0	37.4	25.0	2.9
8.0	28.6	26.0	2.7
9.0	22.6	27.0	2.5
10.0	18.3	28.0	2.3
11.0	15.2	29.0	2.2
12.0	12.7	30.0	2.0
13.0	10.8	31.0	1.9
14.0	9.4	32.0	1.8
15.0	8.1	33.0	1.7
16.0	7.2	34.0	1.6
17.0	6.3	35.0	1.5
18.0	5.7	36.0	1.4

The factors in this table are for a 10-factor prism. Double these factors when using a 20-factor prism.



MSU Upper Peninsula  
Forestry Extension Office 8/99.

Michigan State University programs and materials are open to all without regard to race, color, national origin, gender, religion, age, disability, political beliefs, sexual orientation, marital status, or family status.