

PONSSE

PONSSE



A logger's best friend
www.ponsse.com

Ponsse recommendations to soft terrain

Ponsse's principle has always been to develop productive and efficient solutions for cut-to-length harvesting.

The same principle has been followed also in solutions for soft terrain. Machines specific only for this special purpose are very costly for the entrepreneur, and therefore Ponsse has tried to find the solution by adding special equipment for conventional machines. This means that the solution is more simple, less costly and does not only give access to soft soils but also allows profitable operations in them.

Ponsse recommendations to soft terrain

For soft soils Ponsse recommends PONSSE Fox 8-wheel harvester , PONSSE Ergo 8-wheel harvester, or PONSSE Beaver harvester equipped with PONSSE H53e harvester including multi stemming function. This allows the integrated harvesting of energy- and industrial wood according to current need. The machine combination is well suitable from tending of young stands to thinnings and all the way to smaller sized regeneration fellings.

Ponsse Beaver's front wheels can be equipped with wheel track which increases the ground touching surface appr. by a quarter. This improves the operability in soft terrain remarkably. Also a wider tire can be used. For rear wheels the recommendation is e.g. 916 mm wide Max Magnum general purpose track or equal.

FOX

1. This new 8-wheel thinning machine is well balanced and gentle to forest soil
2. The new type of parallel crane is light weight and the location that is closer to the cabin gives better visibility and 50/50 weight distribution while operating
3. Well known and reliable components have been used to build this machine

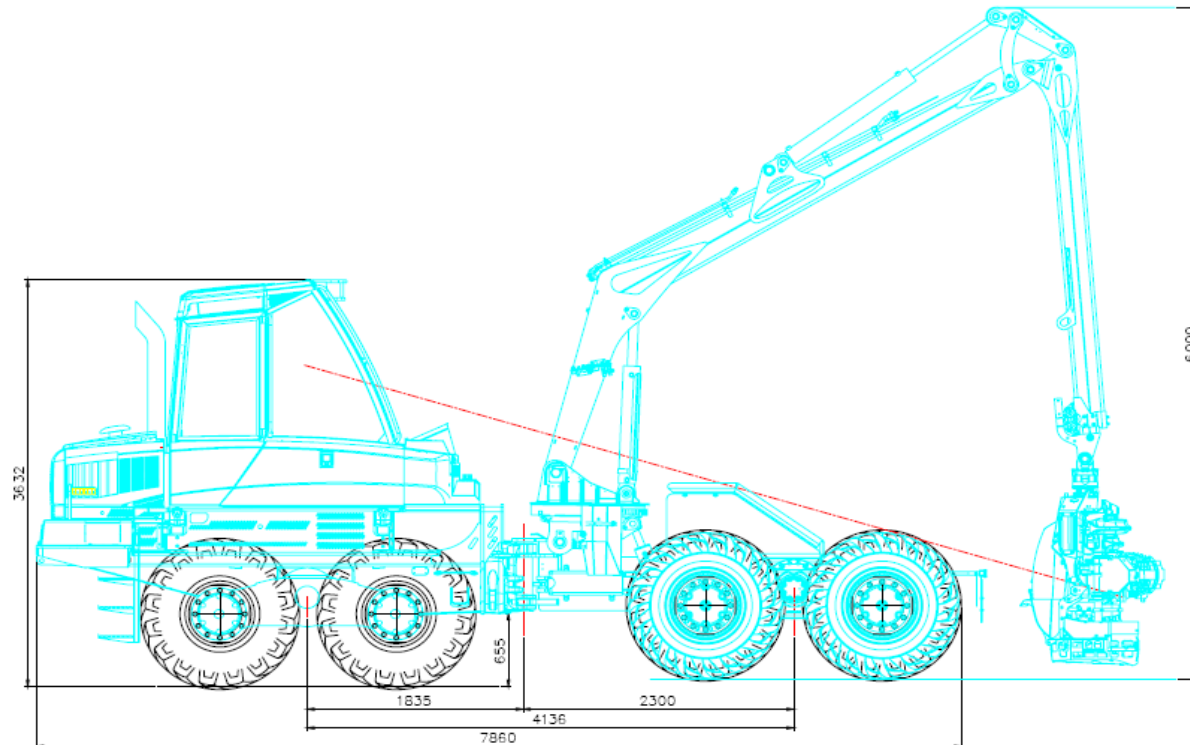

LAYOUT

Drive comfort

- Very stable machine
 - Does not jiggle
 - Operator can work full day without getting tired



Wetlands

- Possibility to use 4 tracks
- Features for operating in wetlands are in the class of it's own
- You can operate with Fox in places were it's hard to walk
- Even 10-w cannot always haul the wood that has been made with fox
- It's easy to drive behind fox with forwarder because soil hasn't been damaged



GROUND PRESSURES



			
Without tracks	6.38 psi	7.69 psi	7.98 psi
With tracks	3.48 psi	4.06 psi	



PONSSE ERGO 8W

1. This 8 wheel multipurpose machine can handle wet soil and steep hills
2. Ponsse has a history of building excellent 8 wheel machines(Cobra)
3. Well known and reliable components have been used for assembling the 8W Ergo

8-WHEEL ERGO

8-wheel drive

- Small ground pressure for wet soil
 - 8 wheel construction adds 1500 kg weight, but front ground pressure is 22% less vs. 6 wheel Ergo
- Excellent hill climbing ability
 - Possibility for balanced bogies and 4 tracks
 - NAF PO 71 balanced bogie
 - 180 kN tractive force(+14%)



8-WHEEL ERGO WEIGHT DISTRIBUTION



Without tracks

7.54 psi

7.83 psi

With tracks

4.06 psi

4.35 psi





Ponsse recommendations to soft terrain

For forwarding we recommend the PONSSE Wisent 10w forwarder with PONSSE Loadoptimizer crane scale. Two additional wheels allow utilizing PONSSE Wisent's full 12 ton capacity and year-round harvesting also in soft soils. The scale allows easy and accurate measuring of the multi—stemming wood.

Track recommendations for PONSSE Wisent 10w are 916 mm Max Magnum or Magnum in rear and 916 mm Eco-Soft or equal in front.

PONSSE 10w

The perfect solution for soft terrain forwarding

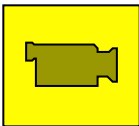

HISTORY

In the summer of 2007 Ponsse participated a project "BEATING THE CHALLENGE OF PEATLAND TIMBER HARVESTING BY USING CONVENTIONAL MACHINES" together with Metsähallitus (Finnish state forest management company) and Metla (Finnish forest research institute). During this project Ponsses own engineers designed a new concept; 10-wheeled forwarder with special tracks. In tests during the project the surface pressures of this machine with 10 ton load remained under 3.48-3.77 psi. A summary of report can be found in Ponsse website.







PONSSE 10w

Principle

The tire size on the additional axle is smaller, 22,5" so that on hard soil these wheels do not touch the ground and the turning radius is similar to 8 wheeler. With the smaller rear wheel the machine also goes smoother over ditches. The last pair of wheels is activated instantly when the machine starts to sink deeper and thus more wheel/track surface is gained.

MARKET AREAS

- Peatlands and other soft soils

The ground pressure of a person weighing 165 lbs is around 3.77 psi – at in tests 10 wheel forwarder equipped Eco magnum tracks (width 1023 mm) front and rear arrived at same ground pressure.* tests carried out by the Metsähallitus, Metla the Finnish Forest Research Institute and Ponsse in 2007

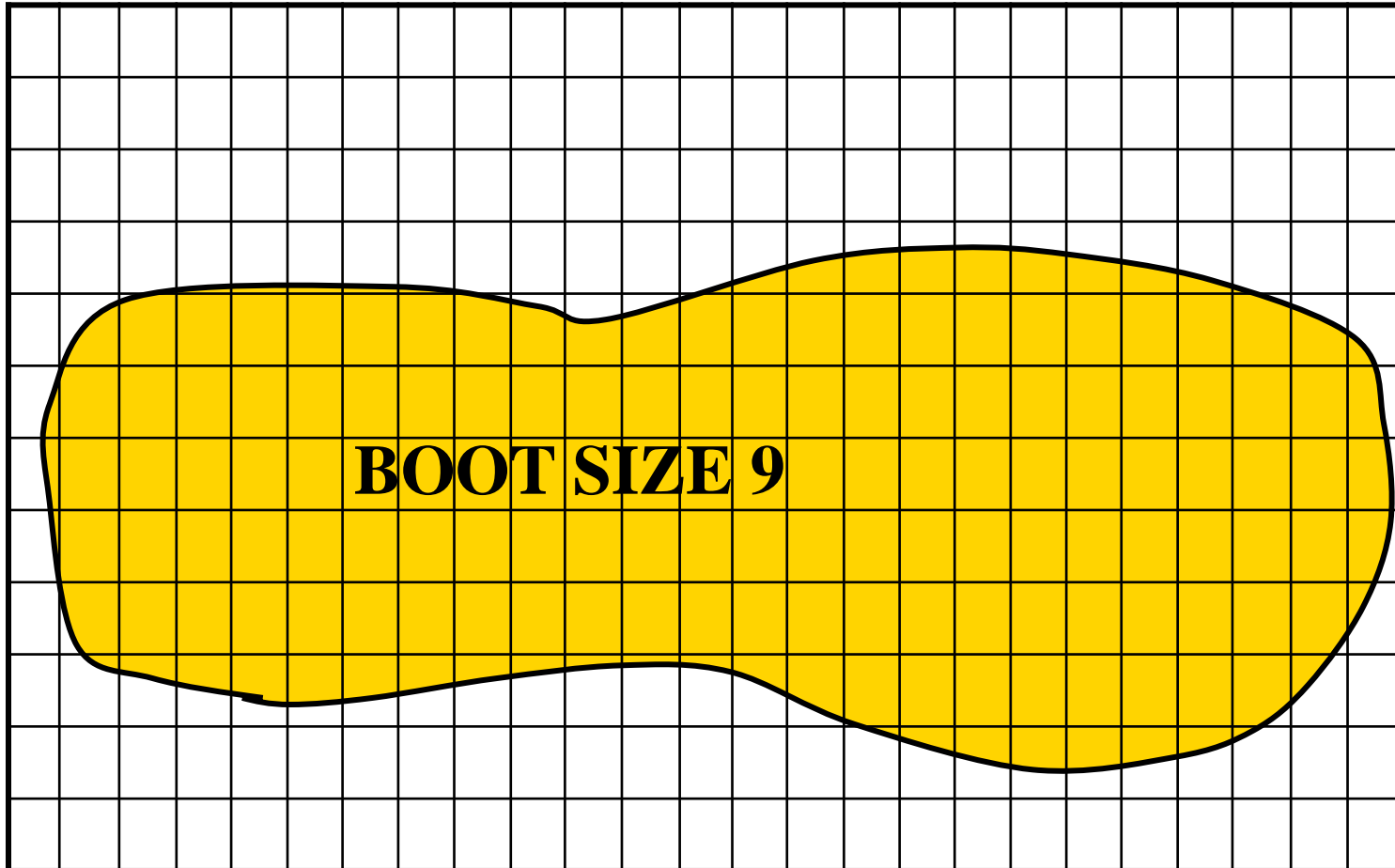

Benefits of 10w

- Forwarder's capacity can be fully utilized. Driving times and thus the fuel consumption are minimized by driving with full loads.
- Added track surface minimizes surface pressure: 70% more track surface in rear
- 10w equipment decreases sideways swinging during driving and crane work
- The operator can utilize his machines year round
- Inexpensive for the owner, does not require any investments in special machinery
- Expands the possibilities to utilize current equipment and generates extra income for the forest owner and entrepreneur
- Gives work for the whole timber procurement chain; year-round utilization of capacity by lengthening the harvesting season

Installation pictures

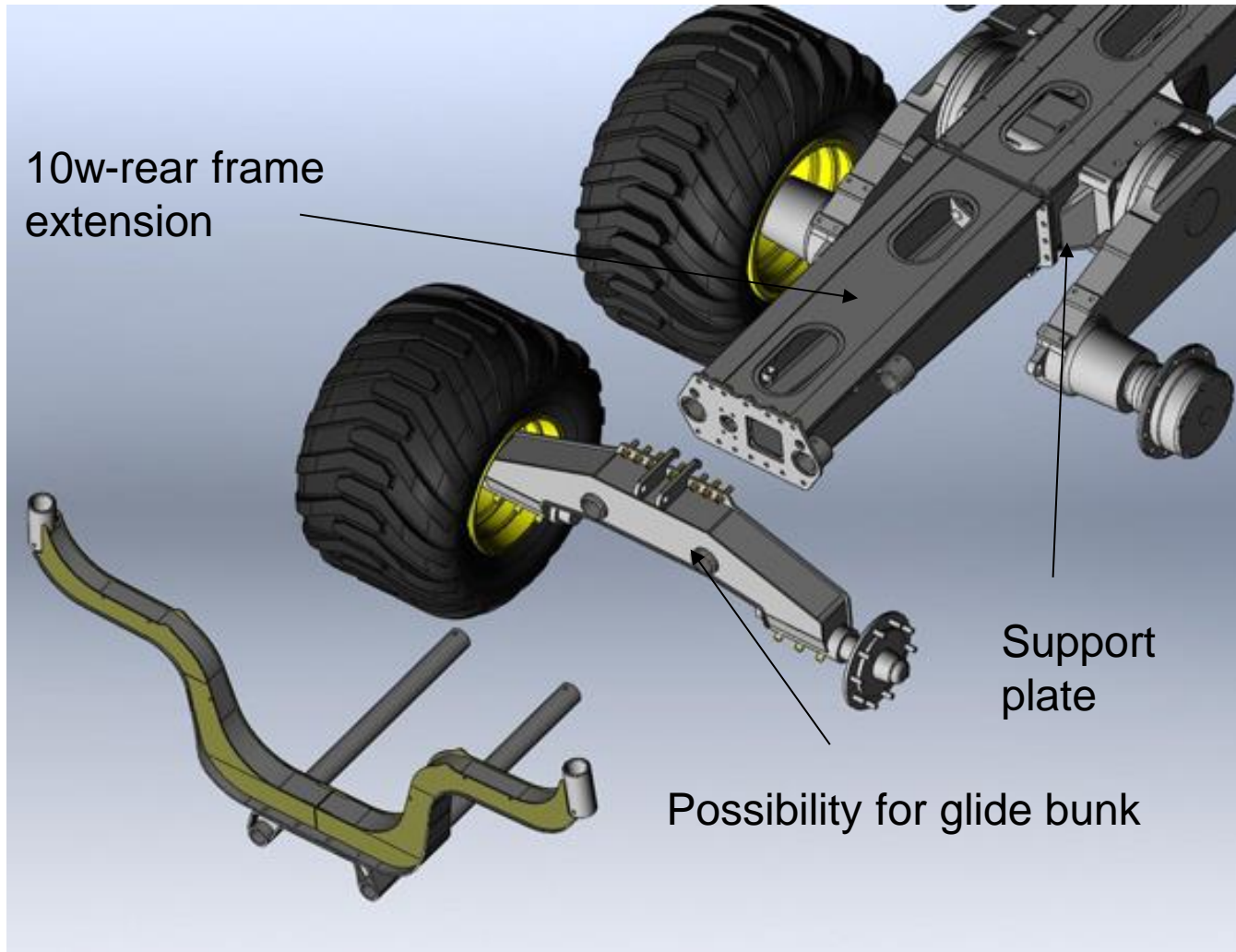

Rear track recommendation



ECO-MaxMagnum 916 mm



ECO-Magnum 916 mm



ECO-Track 850 mm

Front track recommendation



ECO-Magnum 916 mm



ECO-Soft



ECO-Track



PONSSE

A logger's best friend

Ponsse North America, Inc
4400 International Lane
Rhineland, WI 54501
Tel. 715-369-4833
Fax 715-369-4838
www.ponsse.com



A logger's best friend
www.ponsse.com